















# Vichnet Wire Mesh Cable Tray

NINGBO VICHNET TECHNOLOGY CO., LTD

[www.vichnet.com](http://www.vichnet.com)

## ICONS

ICONS	DESCRIPTION
	New Product
	ALL refers to stainless steel materials 304/316/316L and carbon steel processed by electrogalvanizing, hot-dip galvanizing, nickel coating or powder coating.
	Accessories in common use
	Recommended
	Bare/ungalvanized
	An eco-friendly material that emits low smoke and zero halogen when exposed to high sources of heat. Recommended for indoor use.
	Specifically designed and engineered to brace and secure suspended non-structural equipment and components within a building or structure to minimize damage from an earthquake or seismic event. Suitable for HVAC duct, conduit/cable tray, and piping.
	Steel, electrogalvanized according to ISO 2081. Recommended for indoor use.
	Steel, hot dip galvanized according to ISO 1461. Recommended for indoor or outdoor use.
	Steel, Dacromet coated. The zinc- and aluminum-flake coating is appropriate for high corrosion demands. Recommended for indoor and outdoor use.
	Steel, powder coated according to ISO 14922. Recommended for indoor use.
	Steel, nickel plated. The corrosion-resistant, ecofriendly, and cost-efficient finishing effectively prevents the formation of zinc whiskers. Recommended for indoor and outdoor use, especially recommended for use in data centers.
	Steel, pre-galvanized according to EN 10346. Recommended for indoor use.
	Stainless Steel SS304, recommended for indoor or outdoor use, commonly used in food and tobacco industries.
	Stainless Steel SS316, recommended for indoor or outdoor use, commonly for aggressive environments.

## ICONS

ICONS	DESCRIPTION
-------	-------------

S316

Stainless Steel SS316, recommended for indoor or outdoor use, commonly for aggressive environments.

S316L

Stainless Steel SS316L, recommended for indoor or outdoor use, commonly for high aggressive environments, such as marine environments.

Pvc

Polyvinyl chloride, FV-0 flammability (equals to UL94-V0), commonly used for the straight sections of fiber cable trays.

ABS

Acrylonitrile butadiene styrene, FV-0 flammability (equals to UL94-V0), commonly used for the accessories of fiber cable trays.

AL

Aluminum, commonly used for ladder cable trays, solid-bottom cable trays or perforated cable trays.

# CONTENTS

## GENERAL INFORMATION

- | Company Profile
- | Material & Finish
- | Corrosion
- | Warning
- | Certificates
- | Performance Specification
- | Installation Instructions

GI

## WIRE MESH CABLE TRAY SYSTEM

- | CM Series Customized Welding Elbow
- | TCM Self-lock Series
- | CM Special Series
- | Accessories



## FIBER CABLE TRAY SERIES

- | Fiber Cable Tray Straight Section
- | Fiber Cable Tray Accessories





## GENERAL INFORMATION

---

- | Company Profile
- | Material & Finish
- | Corrosion
- | Warning
- | Certificates
- | Performance Specification
- | Installation Instructions



## CONTENTS OF GENERAL INFORMATION

<b>Company Profile</b> -----	005
<b>Certificates</b> -----	007
<b>Material &amp; Finish</b> -----	008
Carbon Steel	
Electrogalvanized	
Hot Dip Galvanized	
Pre-Galvanized	
Powder Coated	
Stainless Steel	
Aluminum	
PVC and ABS	
<b>Performance Specification</b> -----	011
Cable Tray Specification in Common Use	
Safe Working Load Data	
<b>Corrosion</b> -----	012
Atmospheric Corrosion	
Chemical Corrosion	
Storage Corrosion	
Galvanic Corrosion	
<b>Installation Instructions</b> -----	013
Support Span	
Support Installation	
Straight Section Position	
Field Modifications	
Barrier Requirements	
Future Expansion Requirements	
<b>Warning</b> -----	015

## COMPANY PROFILE



Established in 2006, Ningbo Vichnet Technology Co., Ltd is committed to the development, manufacturing, and sales of intelligent safety protection systems. Our cable trays have smooth solder joints, high loading capacities, and are available in a wide variety of product specifications. Our chamfered angle designs effectively prevent cable damage, and the open structure of our wire mesh cable tray products prevent pest infection, mold, and corrosion. Wire mesh cable trays are easy to clean, allow for good heat dissipation, and simplify maintenance and repair procedures. Our products can be flexibly adapted to a wide variety of industrial situations.

Our cable management systems are used in data centers by companies like Alibaba, Huawei, Tencent, Google, on automobile manufacturing lines by companies like Ford, General Motors, Geely, in food manufacturing plants by companies like Budweiser, Wahaha, Evergrande Group, in power plants by companies like Siemens and Tesla, and in cruise ships. Our products are sold to clients from more than 100 countries and regions.

Our manufacturing plant is equipped with fully automated machinery, and complete quality assurance systems. We have obtained the ISO9001 quality management certification, the ISO14001 environmental management certification, the ISO45001 occupational health and safety management certification, and fire safety certifications. Our products have received CE, UL, CUL, and E90 certifications.

As a leading player in China's cable tray industry, Vichnet has participated in formulating a number of national standards for warehouse logistics, food machinery, and communication engineering. We hold more than 100 patents and we have successfully industrialized numerous proprietary technologies, such as nanofilm metal finishing that prevents zinc-whisker formation, intelligent safety system development, and metal mesh protective gear manufacturing technologies.

GENERAL  
INFORMATION

WIRE MESH  
CABLE TRAY

FIBER  
CABLE TRAY







## CERTIFICATES

GENERAL INFORMATION  
WIRE MESH CABLE TRAY  
FIBER CABLE TRAY



UL



CE



E90 Fire Rating



ISO9001



ISO14001

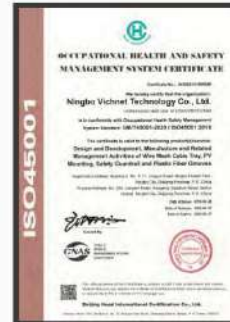

ISO45001













### Product Certificates

- UL
- CUL
- CE
- E90 Fire Rating
- TUV
- SGS

### Management System Certificates

- ISO9001 Quality Management System Certificate
- ISO14001 Environmental Management System Certificate
- ISO45001 Occupational Health and Safety Management System Certificate

## MATERIAL & FINISH

Table 1 Recommended Operating Environment						
Material	Environment	Indoor and Dry	Low Corrosivity (Class 0)	Medium Corrosivity (Class 1)	High Corrosivity (Class 2)	Data Center (ISO14644-1 Standards)
 <b>EZ</b> Electrogalvanized		✓	—	×	×	×
 <b>Hdg</b> Hot Dip Galvanized		—	✓	—	×	✓
 <b>Dac</b> Dacromet		—	✓	—	×	✓
 <b>GI</b> Pre-Galvanized		—	×	×	×	×
 <b>PC</b> Powder Coated		✓	—	×	×	✓
 <b>Ni</b> Nickel Plated		✓	✓	✓	×	✓
 <b>SS304</b>		✓	✓	✓	×	✓
 <b>SS316</b>		✓	✓	✓	×	✓
 <b>SS316L</b>		✓	✓	✓	✓	✓
 <b>AL</b> Aluminum		✓	×	×	×	✓
 <b>Pvc</b> PVC		✓	×	×	×	✓
 <b>Aas</b> ABS		✓	×	×	×	✓
 <b>BL</b> Ungalvanized		×	×	×	×	×

**Remark**  
 (1) ✓ Recommended, - Available, × Not Recommended.  
 (2) Zinc whiskers produced by electro-galvanizing can cause short circuit in the equipment, so electro-galvanizing should not be used in data centers.  
 (3) In data center environments, powder coating can be used on stainless steel, nickel-plated steel, or hot-dip galvanized steel, but should not be used directly on electrogalvanized or pre-galvanized steel products.  
 (4) Refer to Table 2 for corrosivity categories.

**BL Carbon Steel**

Steel cable trays are fabricated from continuous roll-formed high quality carbon steel so that their mechanical properties are enhanced, allowing for the use of a lighter gauge steel to carry the required load. This reduces the dead weight that must be carried by the supports and makes the system easier to install for the contractor. By using high quality carbon steel, Vichnet ensures that the material will meet the minimum yield and tensile strengths required by national standards.

**EZ Electrogalvanized**

Electrogalvanization is the process by which a coating of zinc is deposited on the steel by electrolysis to form a tough, adherent and protective film. This film itself is a barrier coating which slows subsequent corrosive attack on the zinc. This coating is usually only recommended for indoor use in relatively dry areas, as it provides limited protection (ninety-six hours of protection in salt spray).

**Hdg Hot Dip Galvanized**

Hot dip galvanizing is an effective way to protect steel against corrosion. It is commonly used for wire mesh cable trays, channel cable trays and ladder cable trays, etc. Cable trays are completely immersed in a bath of molten zinc. A metallic bond occurs resulting in a zinc coating that completely coats the products surface to provide protection against corrosion.

Hot dip galvanizing is recommended for prolonged outdoor exposure and will protect steel for many years in most outdoor environments as well as in many aggressive industrial environments.

**GI Pre-Galvanized**

Pre-galvanized steel is produced by unwinding steel coil and passing it continuously through a bath of molten zinc and then past air jets to remove excess zinc from the surface. The process is closely controlled to produce a thin, even and ripple free zinc coating with very few imperfections.

Because this pre-galvanized steel coil must be cut to shape during subsequent manufacturing processes, the edges of the finished products will have no zinc coating. This aspect, together with the relatively light zinc coating provided by the process, make pre-galvanized products suitable for indoor, low-corrosive environments, but unsuitable for humid indoor or outdoor applications.

**NI Nickel Plated**

Nickel plating is a proprietary metal finishing technology developed by Vichnet. Nickel plating provides a safe, cost-effective, ecofriendly, abrasion resistant, and corrosion resistant alternative to traditional zinc galvanizing. Nickel plating is particularly suited for data center environments where zinc whiskers pose safety hazards. Vichnet nickel-plated cable trays are manufactured using metal alloy nanofilm formation technology (Vichnet patent), which creates dense, even, and strongly bonded nanometal or alloy films through oxidation-reduction reactions. Recommended for indoor and outdoor use, especially recommended for use in data centers.



#### **PC Powder Coated**

Powder coating may be applied as a protective finish but more generally it is requested as a decorative layer applied to systems already protected by a zinc coating to meet the requirement of color management in modern cable supporting systems.

#### **SS304 SS316 SS316L Stainless Steel**

Stainless steel contains a high proportion of chromium (usually at least 11%) and the steel's remarkable immunity to corrosive attack is conferred by the chromium-rich oxide film which occurs naturally on its surface. For most practical purposes stainless steel can be regarded as maintenance free and suffering no corrosion.

The regular grades of stainless steel to be used for cable trays are SS304, SS316, SS316L. Users can choose what they need according to their application environment, anti-corrosion requirement and budget, etc.

#### **AL Aluminum**

Aluminum cable trays are widely used because of their high strength-to-weight ratio, excellent resistance to certain corrosive environments, and easy installation. Aluminum has exceptional corrosion resistance, including weather resistance, which is attributed to its self-healing and protective surface aluminum oxide film. The aluminum cable tray also has the advantages of being light weight (about 50% of the weight of the steel cable tray) and maintenance-free. In addition, because the aluminum alloy cable tray is non-magnetic, it can minimize electrical loss.

#### **PVC ABS PVC and ABS**

Compared with steel cable tray, plastic cable tray have the features of being light weight and having great atmospheric corrosion resistance. Vichnet fiber cable trays and their covers are made from PVC, and the accessories are made from ABS. Both PVC and ABS are flame retardant rated FV-0 which equals to UL94-V0.



Table 2 Corrosivity Categories					
Reference		Category			
		Indoor and Dry	Low Corrosivity (Class 0)	Medium Corrosivity (Class 1)	High Corrosivity (Class 2)
Main Features of Chemical Corrosion	Operating Conditions	The chemicals can be smelled sometimes.	Due to the wind direction, the chemicals can be smelled sometimes.	The irritation of chemicals can often be felt, but normal process operations can be performed without wearing protective gear.	Strong irritation to eyes or external respiratory tract, sometimes it is necessary to perform normal process operations wearing protective gear.
	Phenomena	The corrosivity is very low. Buildings and facilities have only general rust and corrosion. Process and electrical facilities only need regular maintenance.	Buildings and facilities have only general rust and corrosion. Process and electrical facilities only need regular maintenance. Generally, trees grow normally.	The corrosion of buildings and facilities is obvious. Process and electrical facilities generally require annual overhaul. Generally, trees do not grow well.	The corrosion of buildings and facilities is serious. The interval of equipment overhaul is relatively short. Generally, trees grow shorter.
Ventilation		Normal ventilation conditions	Normal ventilation conditions	Good natural ventilation	Poor ventilation
Installation Sites		Dry and clean indoor site	Inland, far from chemically corrosive substances	Some distance from the seashore, or in places where the concentration of chemically corrosive substances is relatively low	Seashore or places with strong chemically corrosive substances
Humidity and Temperature Characteristics		Low relative humidity	Short durations of high relative humidity	Medium duration of relative humidity	Hot and humid areas with long-term high relative humidity

## PERFORMANCE SPECIFICATION

Cable Tray Specifications in Common Use						
Width \ Height	25	50	75	100	150	200
50	△	△	△	△	△	△
100	△	△				
200	△	△	△			
300	△	△	△	△		
400		△	△	△	△	
500			△	△	△	△
600			△	△	△	△
800			△	△	△	△
1000				△	△	△
1200					△	△

Remark: △ means the specification in common use

Safe Working Load Data					
Wire Diameter 5.0mm		SWL Data ( kg/m )			
		Support Interval			
Height ( mm )	Width ( mm )	1.0m	1.5m	2.0m	3.0m
50	50	91	70	47	23
	100	99	76	51	25
	150	103	79	53	26
100	100	143	110	73	37
	200	159	122	81	41
	300	183	141	94	47
150	200	257	198	132	66
	300	273	240	140	70
	400	285	219	146	73

Remark: The actual maximum load data is twice or three times of SWL data.



### Atmospheric Corrosion

Atmospheric corrosion occurs when metal is exposed to airborne liquids, solids or gases. Some causes of atmospheric corrosion are moisture, salt, dirt and sulfuric acid. This form of corrosion is typically worse outdoors, especially near marine environments.

### Chemical Corrosion

Chemical corrosion takes place when metal comes in direct contact with a corrosive solution. Some factors which affect the severity of chemical corrosion include: chemical concentration level, duration of contact, frequency of washing, and operating temperature.

### Storage Corrosion

Wet storage stain (white rust) is caused by the entrapment of moisture between the surfaces of closely packed and poorly ventilated materials for an extended period of time. Wet storage stain is usually superficial, having no effect on the properties of the metal. Light staining normally disappears with weathering. Medium to heavy buildup should be removed, in order to allow the formation of the normal protective film.

Proper handling and storage will help to ensure stain-free materials. If product arrives wet, it should be unpacked and dried before storage. Dry materials should be stored in a well ventilated low moisture environment to avoid condensation. Outdoor storage is undesirable and should be avoided whenever possible.

### Galvanic Corrosion

Galvanic corrosion occurs when two or more dissimilar metals are in contact while in the presence of an electrolyte (i.e. moisture).

It is very important to consider the effects of electrolytic corrosion when selecting the assembly hardware. Ideally, the finish of the cable tray and hardware should be identical. But if this is not possible, the relatively small hardware should always be higher grade than the large volume tray, e.g. use stainless steel bolts for hot dip galvanized tray but not the other way round.

## INSTALLATION INSTRUCTIONS



Cable management system designs should comply with national standards. It is recommended that installation work is performed by qualified personnel, preferably a certified electrical contractor familiar with standard electrical construction practices, electrical equipment, and the safety of electrical wiring systems.

### Support Span

The strength of a cable tray system is largely determined by the strength of its side rails. The strength of a cable tray side rail is reversely proportionate to the distance between the supports on which it is installed, commonly referred to as the "support span". Therefore, the strength of a cable tray system can be altered by changing the support span. However, there is a limit to how much that strength can be increased by reducing the support span. Once the load requirement has been determined, the following factors should be considered:

- (1) Sometimes the location of existing structural beams will dictate the cable tray support span. This is typical with outdoor installations where adding intermediate supports could be financially prohibitive. For this situation the appropriate cable tray must be selected to accommodate the existing span.
- (2) When cable tray supports are randomly located, the added cost of a higher strength cable tray system should be compared to the cost of additional supports.
- (3) The support span lengths should be equal to or less than unspliced straight section lengths, to ensure that no more than one splice is placed between supports.



### Support Installation

Supports for cable trays should provide strength and working load capabilities sufficient to meet the load requirement of the cable tray wiring system. Consideration should be given to the loads associated with future cable additions or any other additional loads applied to the cable tray system or the cable tray support system.

### Straight Section Position

After the supports are in place, the installation of the cable tray can begin at any place that is convenient. It is not necessary to start at one end of the run. It is ideal to lay out the system so that splice joints fall between the support and the quarter point. This maximizes the rigidity of the cable tray.

### Field Modifications

Cable Tray can be adapted (cut to spec in field situations). These field modifications should be made by qualified personnel only (preferably a certified electrical contractor).

### Barrier Requirements

Barrier strips are used to separate cable systems. The barriers should be made of the same material type as the cable tray. When ordering the barrier, the height must match the loading depth of the cable tray into which it is being installed.

### Future Expansion Requirements

One of the many features of cable trays is the ease of adding cables to an existing system. Future expansion should always be considered when selecting a cable tray, and allowance should be made for additional fill area and load capacity. A minimum of 50% expansion allowance is recommended.

## WARNING



**Cable trays should not be used as a walkway, ladder, or support for people; cable trays are mechanical support system for cables and raceways.**

Using cable trays as a walkway can result in personal injury and also cause damage to the cable tray system and installed cables.

**Hazardous voltages in electrical equipment can cause severe personal injury or death.**

Safety related work practices, as described in national regulations should be followed at all times. The overall performance of a cable tray wiring system is dependent upon proper installation, including the proper installation of supports and cables. Non-achievement to installation and maintenance guidelines may lead to personal injury as well as damage to property.

**Installation and proper maintenance of cable tray wiring systems should be performed only by qualified personnel.**

(1) A qualified installer is one who is familiar with electrical construction. In addition, the person should be: Trained and authorized to test, energize, clear, ground, tag, and lockout circuits in accordance with established safety practices.

(2) Trained in the proper care and use of protective equipment such as insulated rubber gloves, hardhats, safety glasses or face shields, dust masks and flash resistant clothing in accordance with established safety practices and/or local building codes.



GENERAL  
INFORMATION

WIRE MESH  
CABLE TRAY

FIBER  
CABLE TRAY

### Storage

**Aluminum, Fiberglass, Stainless Steel and/or other non-metallic cable trays can be stored outside without protective covering.**

Trays should be loosely stacked, elevated off the ground, and ventilated to prevent storage stain. If appearance is important, cable trays should be stored indoors to prevent water or other environmental factors from staining or adhering to cable trays.

**Hot dipped galvanized, pre-galvanized or electrogalvanized cable trays must be protected or stored in a well ventilated, dry location.**

**PVC or powder coated cable trays should be protected and stored indoors if possible.**  
Cable trays must be protected from scratching and marring of finish.



## FIBER CABLE TRAY SERIES

---

**| Fiber Cable Tray Straight Section**    **| Fiber Cable Tray Accessories**





FIBER CABLE TRAY SECTION

Fiber cable trays are designed to protect and route fiber optic patch cords, multi-fiber cable assemblies, and intrafacility fiber cable (IFC) to and from fiber splice enclosures, fiber distribution frames and fiber optic terminal devices. Fiber cable trays offer ideal solutions for optical raceway requirements and applications requiring an elegant appearance and easy maintenance.

**Features:**

- The closed design protects the fiber optic cables from damage.
- Fiber ducts are made from flame-retardant plastic that has a smooth surface and good appearance.
- Offers excellent bend radius control and ensures fiber radius  $\geq 40$ mm.
- Movable cable exit kits can be used to flexibly meet changing cabling demands in data centers.
- Different kinds of installation methods are available, such as ceiling mounting, cabinet top supporting or connecting with other cable trays.
- The PVC and ABS materials used to make fiber ducts have a flame retardant rating of FV-O.

Fiber Cable Tray Installation

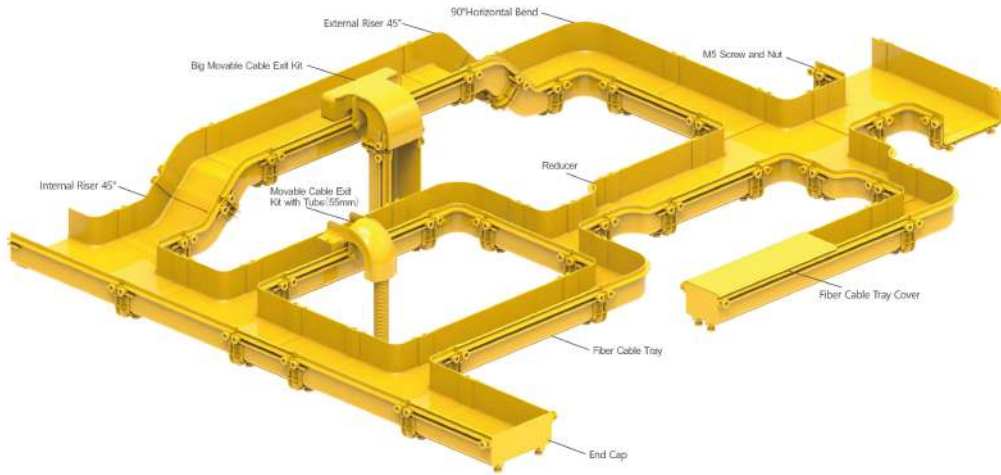

## Fiber Cable Tray Contents

Product Description	Part Number
<b>Fiber Cable Tray Straight Section</b> .....	071
CF120 Fiber Cable Tray	CF120
CF240 Fiber Cable Tray	CF240
CF300 Fiber Cable Tray	CF300
CF360 Fiber Cable Tray	CF360
<b>Fiber Cable Tray Accessories</b> .....	075
Fiber Cable Tray Cover	CF-CVR
Connector	CF-CNT
90°Horizontal Bend	CF-ELB90
90°Horizontal Bend	CF-ELB90CVR
Horizontal Tee	CF-TEE
Horizontal Tee Cover	CF-TEE-CVR-123C
Horizontal Cross	CF-CRS
Horizontal Cross Cover	CF-CRS-CVR-123C
Internal Riser 45°	CF-IRS45
Internal Riser 45° Cover	CF-IRS45-CVR-123C
External Riser 45°	CF-ERS45
External Riser 45° Cover	CF-ERS45-CVR-123C
CF240 to CF120 Vertical Tee	CF240-VTC120
CF240 to CF120 Horizontal Tee	CF240-HTC120
CF240 to CF120 Horizontal Tee Cover	CF240-HTC120-CVR-123C
CF240 to CF120 Reducer	CF240-RDC120
Reducer Cover	CF240-RDC120-CVR-123C
CF300 to CF240 Reducer	CF300-RDC240
CF300 to CF240 Reducer Cover	CF300-RDC240-CVR
CF360 to CF240 Reducer	CF360-RDC240
CF360 to CF240 Reducer Cover	CF360-RDC240-CVR
Trumpet	CF-TSP
End Cap	CF-TTR
Hanging Bar	CF-BARW-123C
Cabinet Top Stand	CF-EFS-123C
Side Hanging Set	CF-HGS-SET-123C
L-Type Support	CF-LW-123C
L-Type Cabinet Top Stand Support	CF-LJQ-123C

## Universal Accessories

089

Movable Cable Exit Kit With Tube ( 55mm )

CF-OUT55

Big Movable Cable Exit Kit

CF-OUT120

Tube ( Diameter=55mm, 50M/Roll )

CF-PIPE55\*50M-123C

M5 Screw

CF-XBOLT

M5 Screw And Nut

CF-XNUT-SET



**CF120 FIBER CABLE TRAY**

Default unit : mm

Part Number	Height	Width	Length	Weight
PC CF120	100	120	2000	4.52kg
AM CF120	100	120	2000	2.79kg



**P/N Definition :**

- CF120: CF means fiber cable tray, 120 means the width 120mm, the height is 100mm, HxW refers to inner size, the length is 2000mm per piece.

**Instruction Manual :**

- Color Code: Pantone 123C

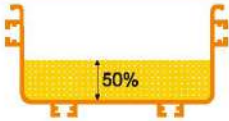
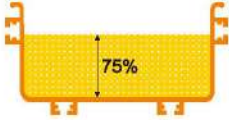
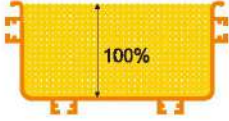
**Fiber Loading Capacity**

2MM Fiber	3MM Fiber	Sectional View
955	424	
1433	636	
1910	848	

## STRAIGHT SECTION

### CF240 FIBER CABLE TRAY

Default unit : mm

Part Number	Height	Width	Length	Weight
PC CF240	100	240	2000	5.88kg
AM CF240	100	240	2000	4.30kg



#### P/N Definition :

- CF240: CF means fiber cable tray, 240 means the width 240mm, the height is 100mm, HxW refers to inner size, the length is 2000mm per piece.

#### Instruction Manual :

- Color Code: Pantone 123C

### Fiber Loading Capacity

2MM Fiber	3MM Fiber	Sectional View
1910	849	50%
2866	1273	75%
3821	1698	100%

**CF300 FIBER CABLE TRAY**

Default unit : mm

Part Number	Height	Width	Length	Weight
 CF300	100	300	2000	7.42kg
 CF300	100	300	2000	5.85kg





**P/N Definition :**

- CF300: CF means fiber cable tray, 300 means the width 300mm, the height is 100mm, HxW refers to inner size, the length is 2000mm per piece.

**Instruction Manual :**

- Color Code: Pantone 123C

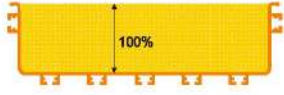
**Fiber Loading Capacity**

2MM Fiber	3MM Fiber	Sectional View
2370	1055	
3556	1578	
5136	2106	

## STRAIGHT SECTION

### CF360 FIBER CABLE TRAY

Default unit : mm

Part Number	Height	Width	Length	Weight
 CF360	100	360	2000	8.08kg
 CF360	100	360	2000	5.96kg



#### P/N Definition :

- CF360: CF means fiber cable tray, 360 means the width 360mm, the height is 100mm, HxW refers to inner size, the length is 2000mm per piece.

#### Instruction Manual :



- Color Code: Pantone 123C

GENERAL  
INFORMATION

WIRE MESH  
CABLE TRAY

FIBER  
CABLE TRAY

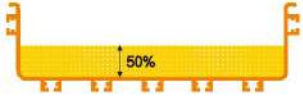
### Fiber Loading Capacity

2MM Fiber	3MM Fiber	Sectional View
2940	1308	
4409	1957	
6369	2611	



**FIBER CABLE TRAY COVER**

Default unit : mm

Part Number	Width	Length	Weight
<b>Pc</b> CF120-CVR	120	2000	1.46kg
<b>Pc</b> CF240-CVR	240	2000	2.92kg
<b>Pc</b> CF300-CVR	300	2000	3.25kg
<b>Pc</b> CF360-CVR	360	2000	5.05kg
<b>Ab</b> CF120-CVR	120	2000	2.79kg
<b>Ab</b> CF240-CVR	240	2000	4.30kg
<b>Ab</b> CF300-CVR	300	2000	5.85kg
<b>Ab</b> CF360-CVR	360	2000	5.96kg

**Instruction Manual :**

- Color Code: Pantone 123C



**CONNECTOR**

Default unit : mm

Part Number	Pack	Weight
<b>Ab</b> CF120-CNT	108pcs	18.60kg
<b>Ab</b> CF240-CNT	68pcs	17.95kg
<b>Ab</b> CF300-CNT	50pcs	17.00kg
<b>Ab</b> CF360-CNT	38pcs	16.06kg

**Instruction Manual :**

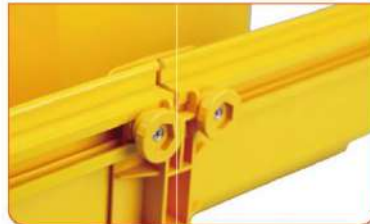
- Application: connects straight sections, etc.
- Includes:
  - CF120 / CF240 connector ×1, M5 screw ×8.
  - CF300 / CF360 connector ×1, M5 screw ×10.
- Features: manufactured from fire-resistant and environment-friendly ABS material.
- Suitable for: CF120 / CF240 / CF300 / CF360 fiber cable tray.



## FIBER CABLE TRAY ACCESSORIES

### 90° HORIZONTAL BEND

Default unit : mm

Part Number	Pack	Weight
ABS CF120-ELB90	24pcs	13.30kg
ABS CF240-ELB90	10pcs	8.90kg
ABS CF300-ELB90	6pcs	9.98kg
ABS CF360-ELB90	10pcs	14.30kg

#### Instruction Manual :

- Application: connects 90° horizontal right angle turn.
- Includes:  
CF120 / CF240 90° horizontal bend ×1, M5 screw and nut ×8.  
CF300 90° horizontal bend ×1, M5 screw and nut ×10.  
CF360 90° horizontal bend ×1.
- Features:  
CF120 / CF240 built-in connector, manufactured from fire-resistant and environment-friendly ABS material.  
CF300 / CF360 built-in connector, manufactured from fire-resistant and environment-friendly ABS + PC material.
- Suitable for: CF120 / CF240 / CF300 / CF360 fiber cable tray.



### 90° HORIZONTAL BEND COVER

Default unit : mm

Part Number	Pack	Weight
ABS CF120-ELB90CVR	100pcs	13.70kg
ABS CF240-ELB90CVR	40pcs	14.48kg

#### Instruction Manual :

- Application: cover for CF120 90° horizontal bend.
- Includes: 90° horizontal bend cover ×1.
- Features: manufactured from fire-resistant and environment-friendly ABS material.



**HORIZONTAL TEE**

Default unit : mm

Part Number	Pack	Weight
Am CF120-TEE	15pcs	10.20kg
Am CF240-TEE	8pcs	11.47kg
Am CF300-TEE	6pcs	13.62kg
Am CF360-TEE	10pcs	18.90kg

**Instruction Manual :**

- Application: connects horizontal tee.
- Includes:
  - CF120 / CF240 horizontal tee ×1, M5 screw and nut ×12.
  - CF300 horizontal tee ×1, M5 screw and nut ×15.
  - CF360 horizontal tee ×1.
- Features:
  - CF120 / CF240 built-in connector, manufactured from fire-resistant and environment-friendly ABS material.
  - CF300 / CF360 built-in connector, manufactured from fire-resistant and environment-friendly ABS+PC material.
- Suitable for: CF120 / CF240 / CF300 / CF360 fiber cable tray.

**HORIZONTAL TEE COVER**

Default unit : mm

Part Number	Pack	Weight
Am CF120-TEE-CVR	50pcs	10.25kg
Am CF240-TEE-CVR	30pcs	15.10kg

**Instruction Manual :**

- Application: cover For CF120 / CF240 horizontal tee.
- Includes: CF120 / CF240 horizontal tee ×1.
- Features: manufactured from fire-resistant and environment-friendly ABS material.



## FIBER CABLE TRAY ACCESSORIES

### HORIZONTAL CROSS

Default unit : mm

Part Number	Pack	Weight
ABS CF120-CRS	10pcs	8.62kg
ABS CF240-CRS	8pcs	12.07kg
ABS CF300-CRS	3pcs	9.29kg
ABS CF360-CRS	10pcs	21.00kg

#### Instruction Manual :

- Application: connects horizontal cross.
- Includes:
  - CF120 / CF240 horizontal cross ×1, M5 screw and nut ×16.
  - CF300 / CF360 horizontal cross ×1, M5 screw and nut ×20
- Features: CF120 / CF240 built-in connector, manufactured from fire-resistant and environment-friendly ABS material.
- CF300 / CF360 built-in connector, manufactured from fire-resistant and environment-friendly ABS+PC material.
- Suitable for: CF120 / CF240 / CF300 / CF360 fiber cable tray.

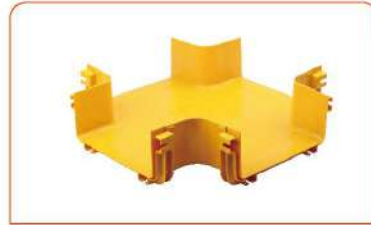

### HORIZONTAL CROSS COVER

Default unit : mm

Part Number	Pack	Weight
ABS CF120-CRS-CVR	40pcs	11.00kg
ABS CF240-CRS-CVR	30pcs	15.17kg

#### Instruction Manual :

- Application: cover for CF120 / CF240 horizontal cross.
- Includes: CF120 / CF240 horizontal cross cover ×1.
- Features: manufactured from fire-resistant and environment-friendly ABS material.





**INTERNAL RISER 45°**

Default unit : mm

Part Number	Pack	Weight
Ab CF120-IRS45	32pcs	15.80kg
Ab CF240-IRS45	20pcs	9.93kg
Ab CF300-IRS45	20pcs	11.00kg
Ab CF360-IRS45	30pcs	16.10kg

**Instruction Manual :**

- Application: raises or lowers cable tray elevation, used in combination with external riser 45°.
- Includes: internal riser 45° ×1.
- Features: manufactured from fire-resistant and environment-friendly ABS material.
- Suitable for: CF120 / CF240 / CF300 / CF360 fiber cable tray.

**INTERNAL RISER 45°COVER**

Default unit : mm

Part Number	Pack	Weight
Ab CF120-IRS45-CVR	180pcs	16.48kg
Ab CF240-IRS45-CVR	160pcs	33.60kg

**Instruction Manual :**

- Application: cover for CF120 / CF240 internal riser 45°.
- Includes: internal riser 45° cover ×1.
- Features: manufactured from fire-resistant and environment-friendly ABS material.



## FIBER CABLE TRAY ACCESSORIES

### EXTERNAL RISER 45°

Default unit : mm

Part Number	Pack	Weight
Abi CF120-ERS45	32pcs	10.25kg
Abi CF240-ERS45	32pcs	7.69kg
Abi CF300-ERS45	20pcs	9.20kg
Abi CF360-ERS45	30pcs	13.40kg

#### Instruction Manual :

- Application: raises or lowers cable tray elevation, used in combination with internal riser 45°.
- Includes: CF120 external riser 45° x1.
- Features: manufactured from fire-resistant and environment-friendly ABS material.
- Suitable for: CF120 / CF240 / CF300 / CF360 fiber cable tray.



### EXTERNAL RISER 45°COVER

Default unit : mm

Part Number	Pack	Weight
Abi CF120-ERS45-CVR	270pcs	16.66kg
Abi CF240-ERS45-CVR	100pcs	23.75kg

#### Instruction Manual :

- Application: cover for CF120 / CF240 external riser 45°.
- Include: external riser 45° cover x1.
- Feature: manufactured from fire-resistant and environment-friendly ABS material.



**CF240 TO CF120 HORIZONTAL TEE**

Default unit : mm

Part Number	Pack	Weight
 CF240-VTC120	7pcs	5.02kg

**Instruction Manual :**

- Application: connect CF240 to CF120 vertical straight sections.
- Includes: CF240 to CF120 vertical tee ×1, M5 screw and nut ×12.
- Features: manufactured from fire-resistant and environment-friendly ABS material.
- Suitable for: CF240 to CF120 fiber cable tray.

**CF240 TO CF120 HORIZONTAL TEE**

Default unit : mm

Part Number	Pack	Weight
 CF240-HTC120	10pcs	9.44kg

**Instruction Manual :**

- Application: horizontal tee connections for CF240 to CF120 fiber cable tray.
- Includes: CF240 to CF120 horizontal tee ×1, M5 screw ×12.
- Features: built-in connector, manufactured from fire-resistant and environment-friendly ABS material.
- Suitable for: CF240 to CF120 fiber cable tray.



## FIBER CABLE TRAY ACCESSORIES

GENERAL INFORMATION  
WIRE MESH  
CABLE TRAY  
FIBER CABLE TRAY

### CF240 TO CF120 HORIZONTAL TEE COVER

Default unit : mm

Part Number	Pack	Weight
 CF240-HTC120-CVR	80pcs	28.40kg

#### Instruction Manual :

- Application: cover for CF240 to CF120 horizontal tee.
- Includes: CF240 to CF120 horizontal tee cover ×1.
- Features: manufactured from fire-resistant and environment-friendly ABS material.

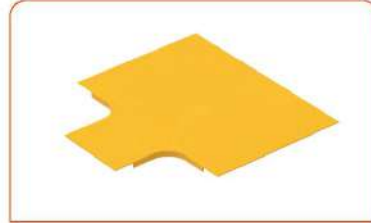

### CF240 TO CF120 REDUCER

Default unit : mm

Part Number	Pack	Weight
 CF240-RDC120	24pcs	10.54kg

#### Instruction Manual :

- Application: horizontal connection for CF240 to CF120 reducing.
- Includes: horizontal connection for CF240 to CF120 reducer ×1, M5 screw and nut ×8.
- Features: built-in connector, manufactured from fire-resistant and environment-friendly ABS material.
- Suitable for: CF240 to CF120 fiber cable tray.





**CF240 TO CF120 REDUCER COVER**

Default unit : mm

Part Number	Pack	Weight
 CF240-RDC120-CVR	270pcs	31.70kg

**Instruction Manual :**

- Application: cover for CF240 to CF120 reducer.
- Includes: CF240 to CF120 reducer cover ×1.
- Features: manufactured from fire-resistant and environment-friendly ABS material.

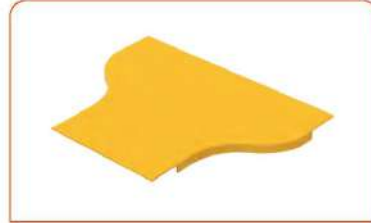
**CF300 TO CF240 REDUCER**

Default unit : mm

Part Number	Pack	Weight
 CF300-RDC240	16pcs	9.84kg

**Instruction Manual :**

- Application: horizontal connection for CF300 to CF240 reducing.
- Includes: horizontal connection for CF300 to CF240 reducer ×1, M5 screw and nut ×9.
- Features: built-in connector, manufactured from fire-resistant and environment-friendly ABS material.
- Suitable for: CF300 to CF240 fiber cable tray.



## FIBER CABLE TRAY ACCESSORIES

GENERAL INFORMATION  
WIRE MESH  
CABLE TRAY  
FIBER CABLE TRAY

### CF300 TO CF240 REDUCER COVER

Default unit : mm

Part Number	Pack	Weight
 CF300-RDC240-CVR	120pcs	28.40kg

#### Instruction Manual :

- Application: cover for CF300 to CF240 reducer.
- Includes: CF300 to CF240 reducer cover ×1.
- Features: manufactured from fire-resistant and environment-friendly ABS material.



### CF360 TO CF240 REDUCER

Default unit : mm

Part Number	Pack	Weight
 CF360-RDC240	4pcs	3.88kg

#### Instruction Manual :

- Application: horizontal connection for CF360 to CF240 reducing.
- Includes: horizontal connection for CF360 to CF240 reducer ×1, M5 screw and nut ×9.
- Features: built-in connector, manufactured from fire-resistant and environment-friendly ABS material.
- Suitable for: CF360 to CF240 fiber cable tray.

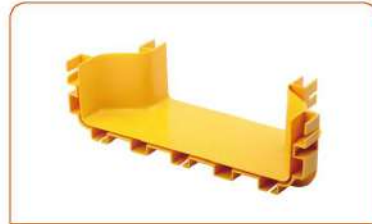

**CF360 TO CF240 REDUCER COVER**

Default unit : mm



Part Number	Pack	Weight
 CF360-RDC240-CVR	50pcs	11.00kg

**Instruction Manual :**

- Application: cover for CF360 to CF240 reducer.
- Includes: CF360 to CF240 reducer cover ×1.
- Features: manufactured from fire-resistant and environment-friendly ABS material.

**TRUMPET**

Default unit : mm

Part Number	Pack	Weight
 CF120-TSP	50pcs	5.83kg
 CF240-TSP	40pcs	3.52kg
 CF300-TSP	20pcs	4.10kg

**Instruction Manual :**

- Application: connection to straight section or big movable cable exit for cable drop-out.
- Includes: trumpet x1, M5 screw and nut x4.
- Features: bend radius protects cables against damage when dropping out.
- Suitable for: CF120 / CF240 / CF300 fiber cable tray.



## FIBER CABLE TRAY ACCESSORIES

### END CAP

Default unit : mm

Part Number	Pack	Weight
Am CF120-TTR	400pcs	18.28kg
Am CF240-TTR	240pcs	17.38kg
Am CF300-TTR	39pcs	5.51kg
Am CF360-TTR	39pcs	6.68kg

#### Instruction Manual :

- Application: close the ends.
- Includes:
  - CF120 / CF240 end cap ×1, M5 screw and nut ×4.
  - CF300 / CF360 end cap ×1, M5 screw and nut ×5.
- Features: manufactured from fire-resistant and environment-friendly ABS material, closed, beautiful and clean.
- Suitable for: CF300 fiber cable tray.



### HANGING BAR

Default unit : mm

Part Number	Length	Width	Weight
Am CF-BAR120-123C	249	48	0.45kg
Am CF-BAR240-123C	365	48	0.55kg
Am CF-BAR300-123C	423	48	0.66kg
Am CF-BAR360-123C	481	48	0.78kg



#### Instruction Manual :

- Application: hanging installation for CF300 fiber cable tray.
- Includes: supporting bar x1, M5 screw x2.
- Suitable for: CF120 / CF240 / CF300 / CF360 fiber cable tray.





**CABINET TOP STAND**

Default unit : mm

Part Number	Length	Width	Weight
As CF120-EFS-123C	249	120	0.88kg
As CF240-EFS-123C	365	120	1.03kg
As CF300-EFS-123C	423	120	1.10kg
As CF360-EFS-123C	481	120	1.17kg



**Instruction Manual :**

- Application: supports cabinet top stand installation, height can be customized.
- Includes: supporting bar x1, cabinet support kit x2, screw x2, M10x20 bolt x6, M10 nut x6.
- Suitable for: CF120 / CF240 / CF300 / CF360 fiber cable tray.

**SIDE HANGING SET**

Default unit : mm

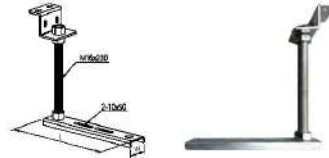
Part Number	Length	Width	Weight
As CF120-HGS-SET-123C	249	48	1.00kg
As CF240-HGS-SET-123C	365	48	1.20kg
As CF300-HGS-SET-123C	423	48	1.30kg
As CF360-HGS-SET-123C	481	48	1.36kg

**Instruction Manual :**

- Application: used with aluminum alloy cable ladder or U channel cable ladder supporting.
- Includes: CF120 / CF240 / CF300 / CF360 supporting bar x1, Z-type kit x1, M16 thread rod x1, screw x2, M6x16 bolt x4, M6 diamond nut x4, M16 nut x4.
- Suitable for: CF120 / CF240 / CF300 / CF360 fiber cable tray.



## FIBER CABLE TRAY ACCESSORIES

### L-TYPE SUPPORT

Part Number	Length	Width	Weight
Am CF-L120-123C	168	100	0.30kg
Am CF-L240-123C	284	130	0.45kg
Am CF-L300-123C	342	130	0.78kg
Am CF-L360-123C	400	130	0.98kg

#### Instruction Manual :

- Application: support CF120 / CF240 / CF300 / CF360 fiber cable tray.
- Includes: CF120 / CF240 / CF300 / CF360 L-type support x1, M5 screw x2.
- Suitable for: CF120 / CF240 / CF300 / CF360 fiber cable tray.



Default unit : mm

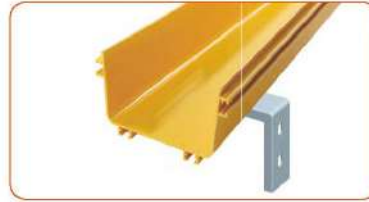

GENERAL INFORMATION

WIRE MESH CABLE TRAY

FIBER CABLE TRAY

**MOVABLE CABLE EXIT KIT WITH TUBE ( 55MM )**

Default unit : mm

Part Number	Pack	Weight
 CF-OUT55	20pcs	17.73kg

**Instruction Manual :**

- Application: directing fibers out of fiber cable tray and into cabinet.
- Includes:
  - ①1 PC small movable cable exit cover.
  - ②1 PC small movable cable exit base,
  - ③1 PC tube-fixer,
  - ④2 sets screws and nuts,
  - ⑤1 PC tube, diameter 55mm, length 800mm.
- Features: manufactured from fire-resistant and environment-friendly ABS material, combined installation, easy and convenient installation, beautiful.
- Suitable for: all sizes of fiber cable trays.



**BIG MOVABLE CABLE EXIT KIT**

Default unit : mm

Part Number	Pack	Weight
 CF-OUT120	15pcs	7.47kg

**Instruction Manual :**

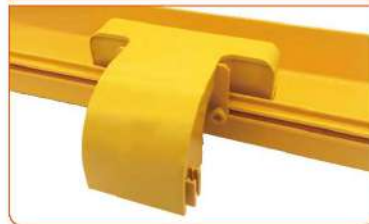
- Application: directing more fibers out of fiber cable tray and into cabinet.
- Includes:
  - ①1 PC large movable cable exit cover,
  - ②1 PC large movable cable exit base,
  - ③2 sets screws and nuts.
- Features: manufactured from fire-resistant and environment-friendly ABS material, can be connected with 120mm fiber duct or trumpet as a exit kit for large quantity fibers.
- Suitable for: all sizes of fiber cable trays.



## UNIVERSAL ACCESSORIES

GENERAL  
INFORMATION

WIRE MESH  
CABLE TRAY

FIBER  
CABLE TRAY

### TUBE ( 55MM )

Default unit : mm

Part Number	Pack	Weight
▲ CF-PIPE55x50M	50pcs	8.00kg

#### Instruction Manual :

- Application: drops fiber optical cables.
- Includes: 50M / roll, diameter 55mm, 65 PCS of tube fixes.
- Features: manufactured from fire-resistant and environment-friendly PP material, closed, beautiful and clean.



### M5 SCREW

Default unit : mm

Part Number	Pack	Weight
▲ CF-XBOLT	100pcs	0.79kg

#### Instruction Manual :

- Application: fixes connectors.



**M5 SCREW AND NUT**

Default unit : mm

Part Number	Pack	Weight
 CF-XNUT-SET	100pcs	1.13kg

**Instruction Manual :**

- Application: fixes different bends.

